

Floor Screen Booth System 50 Square

KURAGE[®]
acoustic design solutions



Booths are supplied in three combination possibilities, all with a height of 140-155 cm.

The cover has elastics sewn on, ensuring a constant tightening of the fabric. Cover is detachable and can be dry-cleaned.

Possibility for printed as well as plain textiles.

Visible frame of extruded aluminium.

Acoustic core of stone wool/mineral wool made from natural minerals.

Thickness: 50 mm.

In addition to standard dimensions we also supply special dimensions.

Combinations

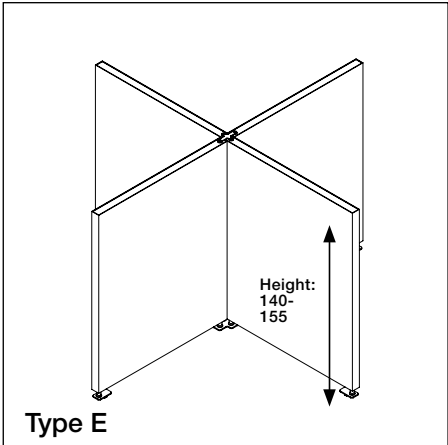
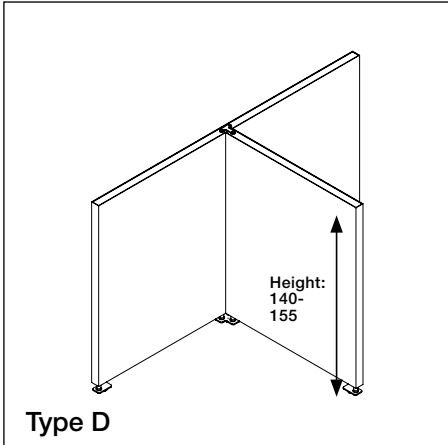
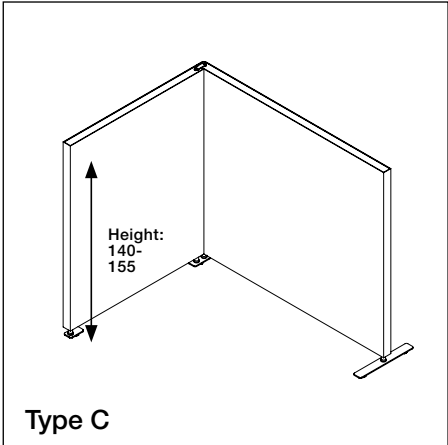
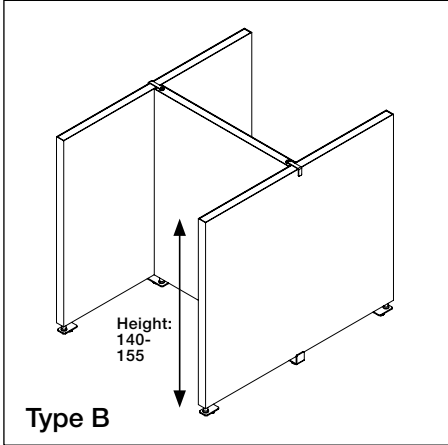
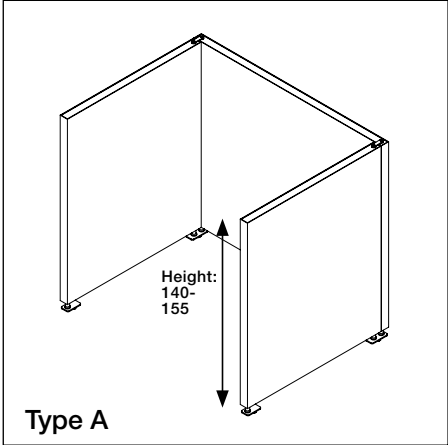

Acoustic properties

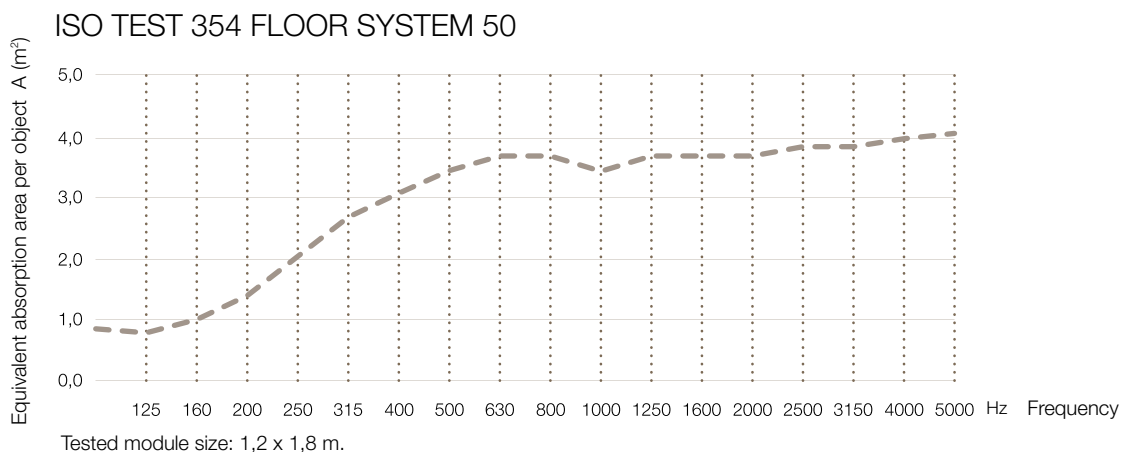

Accessories 1/2

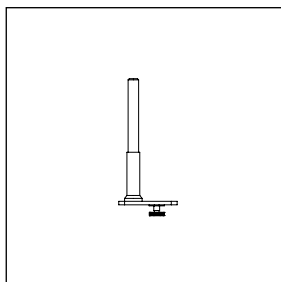

Adjustable foot article no. 5220

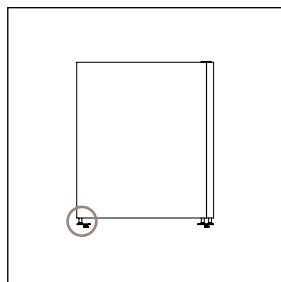

Adjustable foot article no. 5220

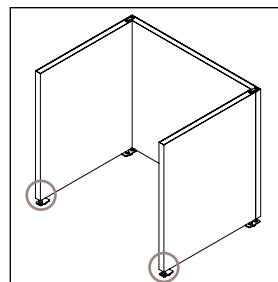

Adjustable foot article no. 5220

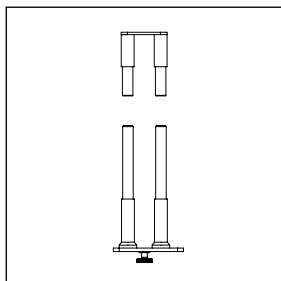

Connecting bracket article no. 5221

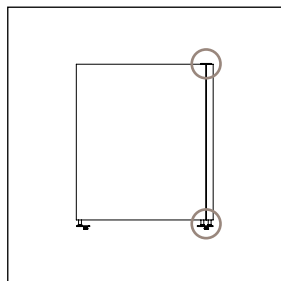

Connecting bracket article no. 5221

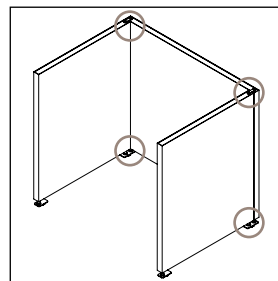

Connecting bracket article no. 5221

Accessories 2/2

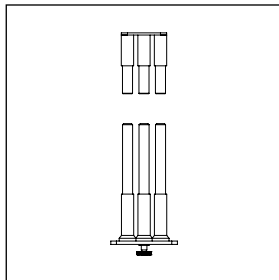

Connecting bracket article no. 5222

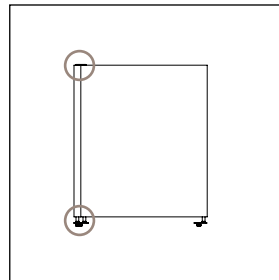

Connecting bracket article no. 5222

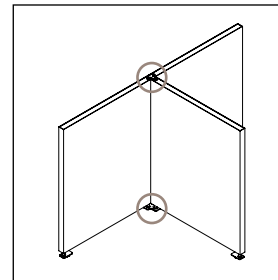

Connecting bracket article no. 5222

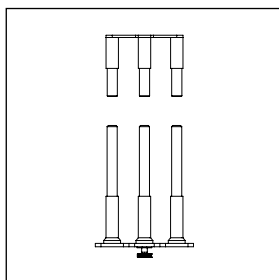

Connecting bracket article no. 5223

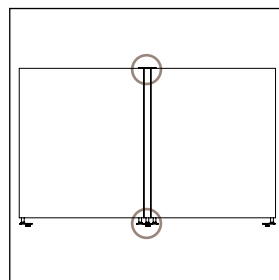

Connecting bracket article no. 5223

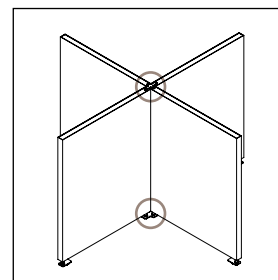

Connecting bracket article no. 5223

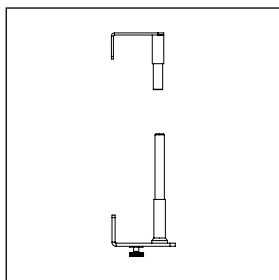

Connecting bracket article no. 5224

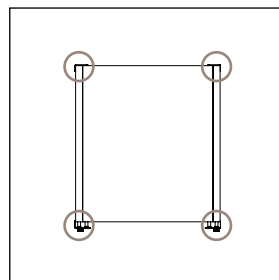

Connecting bracket article no. 5224

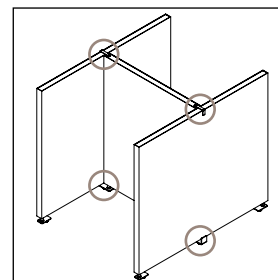

Connecting bracket article no. 5224

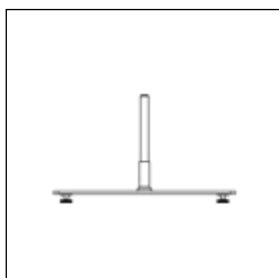

Square adjustable foot article no. 5021

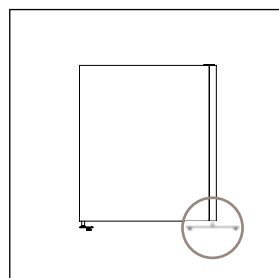

Square adjustable foot article no. 5021

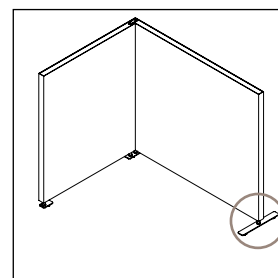

Square adjustable foot article no. 5021