

ACOUSTIC TABLE SCREENS



KURAGE

www.kurage.com

REFINING WORKSPACES WITH ACOUSTIC TABLE SCREENS

ACOUSTIC TABLE SCREENS redefine the concept of workspace optimisation by merging exceptional acoustic management with functional design. Offering the Basic and RE-cover models, our collection is tailored to enhance the auditory experience while simultaneously injecting a visual flair into your table set-ups. These screens are not just about sound absorption; they're about creating an aesthetically pleasing and focused work environment.

Together, the Basic and RE-cover Acoustic Table Screens offer a comprehensive solution for enhancing work and study areas. They bring not only improved acoustics but also a touch of elegance and personalisation to desks and meeting tables, making them ideal for a variety of settings. Whether you're looking to create a serene home office or a productive communal workspace, our Acoustic Table Screens provide the perfect blend of style, functionality, and acoustic privacy.



MODELS

Dive into our Acoustic Table Screen collection, featuring two meticulously designed models: Basic and RE-cover. Each model is crafted to meet diverse needs, ensuring that your workspace not only sounds but also looks its best.

BASIC

The Basic model is the essence of classic design reimagined for the modern workspace. It boasts a traditional square shape with clean, precise lines, complemented by a durable, permanent cover. This model offers simplicity and stability in acoustic solutions, making it a steadfast choice for those seeking minimalistic elegance. Available with both rounded and square corner endings, Basic effortlessly matches any office decor, providing a uniform look that enhances the room's acoustics without drawing undue attention to itself.



RE-COVER

For those who prioritise flexibility and style, the RE-cover model is unparalleled. It features a practical, removable cover, allowing for easy maintenance or style updates to suit changing preferences or branding needs. Additionally it features elegant aluminium trims on two sides. Whether you prefer the softness of rounded edges or the sharp, contemporary feel of square tops and bottoms, RE-cover adapts to your space and style. This model is designed for dynamic environments where aesthetics and functionality go hand in hand, offering an effective acoustic solution that's as versatile as it is visually appealing.



COLLECTION

For all Kurage acoustic products we have meticulously selected several distinct types of textiles, each presenting a palette of colours to match your aesthetic and design needs. Listed are the names of the textiles available in our collection: Dotty, Woolen, Converted Melange, Quest, In the Dark, In the Dark Melange, Wonder, Carlow, Meta and Blue collection.



MATERIALS

In crafting our Acoustic Table Screens, we employ only the finest materials to ensure durability, performance, and aesthetic appeal:

FRAMES AND TRIMS, RE-COVER:

Extruded from 100% aluminium, providing a sturdy and elegant framework that complements any space.

FRAMES, BASIC:

Constructed in wood.

FITTINGS:

Constructed from 100% aluminium, providing a sturdy table fixation.

ACOUSTIC CORE:

Comprised of stone wool/mineral wool, made from natural materials. This core is essential for the screens' superior sound-absorbing capabilities, effectively managing acoustics in a variety of environments.

TEXTILE COVERS:

Our covers are available in a variety of textiles, primarily consisting of polyester or a blend of wool, available in various colours and material compositions as per our collection. RE-cover also incorporate sewn-in elastics to ensure the removable textile cover remains taut and neatly in place, enhancing both functionality and visual appeal.



METAL COLOURS

RE-cover table screen aluminium trims come in a standard sleek silver anodised aluminium finish and are also available in standard lacquered grey, white and black. Additionally, seven other design colours are offered for optimal customisation. All fittings are exclusively available in the ten lacquered colours. This range ensures that RE-cover table screens not only offer superior acoustic performance but also seamlessly match any design aesthetic or branding needs. The available colours with RAL codes are as follows:

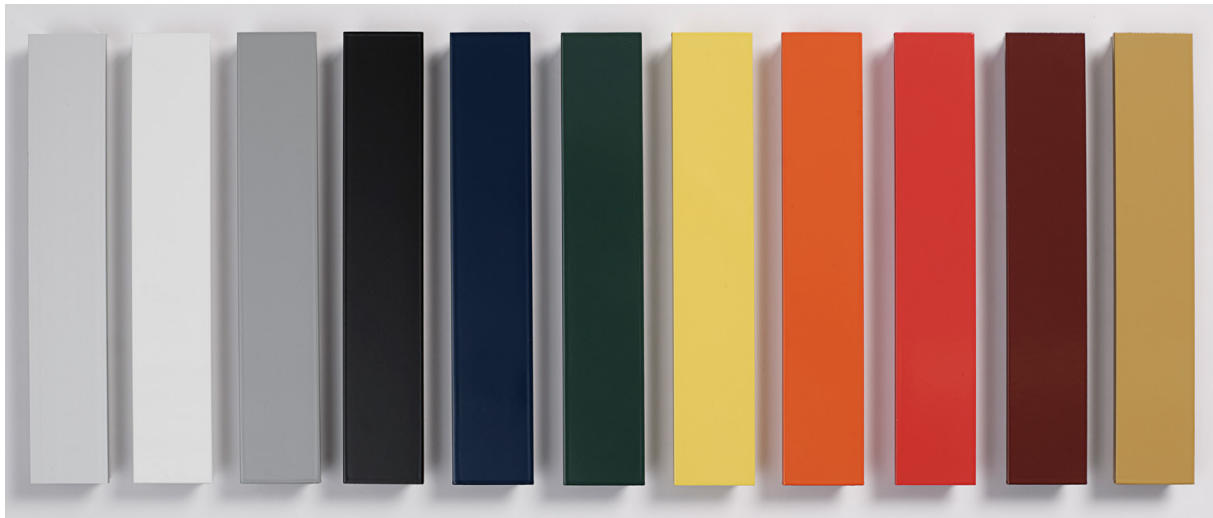

Anodised	White 9003	Grey 7042	Black 9005	Dark blue 5003	Dark green 6028	Yellow 1018	Orange 2009	Red 3028	Rust red 3009	Okker 1024
----------	---------------	--------------	---------------	-------------------	--------------------	----------------	----------------	-------------	------------------	---------------

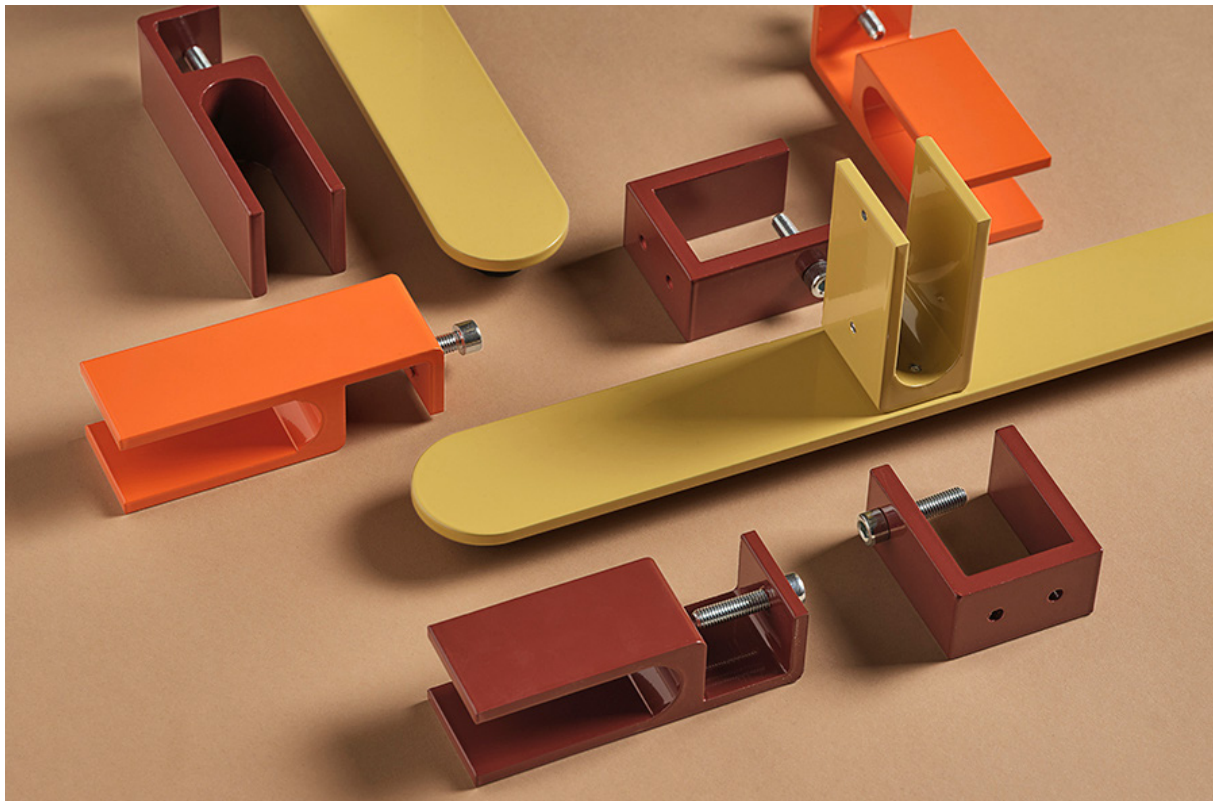

PRODUCT SPECIFICATION

TABLE SCREEN BASIC SQUARE

	MODEL SIZE	MAX. WIDTH	MAX. HEIGHT
	30 Thickness: 30 mm	200 cm	80 cm
	40 Thickness: 40 mm	200 cm	80 cm
	50 Thickness: 50 mm	200 cm	80 cm

TABLE SCREEN BASIC ROUNDED

	MODEL SIZE	MAX. WIDTH	MAX. HEIGHT
	30 Thickness: 30 mm	200 cm	80 cm
	40 Thickness: 40 mm	200 cm	80 cm
	50 Thickness: 50 mm	200 cm	80 cm

TABLE SCREEN RE-COVER SQUARE

	MODEL SIZE	MAX. WIDTH	MAX. HEIGHT
	50 Thickness: 54 mm	200 cm	80 cm

TABLE SCREEN RE-COVER ROUNDED

	MODEL SIZE	MAX. WIDTH	MAX. HEIGHT
	30 Thickness: 27 mm	200 cm	80 cm
	50 Thickness: 54 mm	200 cm	80 cm

ACCESSORIES

Enhance and personalise your workspace with our comprehensive range of mounting options for Acoustic Table Screens. These accessories ensure that your screens can be affixed to the table in various ways, catering to the unique requirements of your space. We have the following types of fittings available:

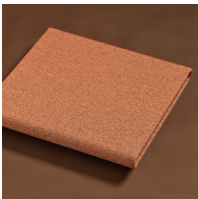
- **FRONT MOUNTED FITTINGS:** Secure your screen from the front with a discretely hidden attachment to the bottom side of the table, perfect for a minimalistic setup.
- **CLAMP FITTINGS:** Offer flexibility and ease of installation with a non-permanent attachment that can be adjusted or removed as required, ideal for changing workspace needs.
- **TABLE TOP FITTINGS:** These provide a stable, permanent solution for attaching your screens on top of the table, ensuring they remain firmly in place even in high-traffic areas.

FRONT MOUNTED FITTING

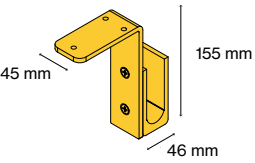
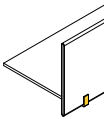
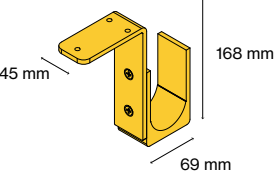
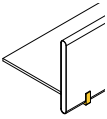
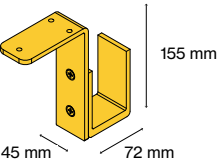
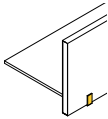
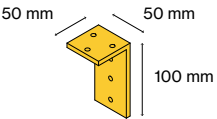
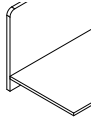
RE-COVER ROUNDED 30	RE-COVER ROUNDED 50	RE-COVER SQUARE 50	BASIC ROUNDED & SQUARE 30, 40 & 50
 <p>45 mm 155 mm 46 mm</p> <p>art. no. 3032</p> 	 <p>45 mm 168 mm 69 mm</p> <p>art. no. 5032</p> 	 <p>45 mm 155 mm 72 mm</p> <p>art. no. 5033</p> 	 <p>50 mm 50 mm 100 mm</p> <p>art. no. 3040</p> 

CLAMP FITTING

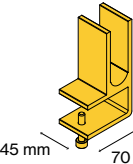
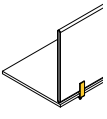
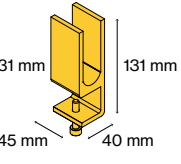
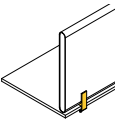
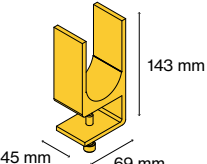
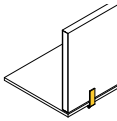
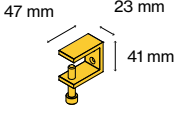
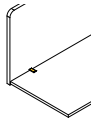
RE-COVER ROUNDED 30	RE-COVER ROUNDED 50	RE-COVER SQUARE 50	BASIC ROUNDED & SQUARE 30, 40 & 50
 <p>45 mm 70 mm 131 mm</p> <p>art. no. 3029</p> 	 <p>45 mm 69 mm 143 mm</p> <p>art. no. 5030</p> 	 <p>45 mm 66 mm 131 mm</p> <p>art. no. 5034</p> 	 <p>47 mm 23 mm 41 mm</p> <p>art. no. 3041</p> 

ACCESSORIES

TABLE TOP FITTING

RE-COVER
ROUNDED 30

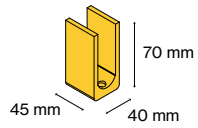

art. no. 3031

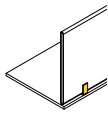

RE-COVER
ROUNDED 50

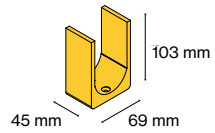

art. no. 5031

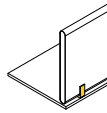

RE-COVER
SQUARE 50

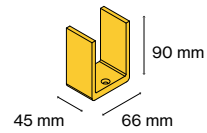

art. no. 5035

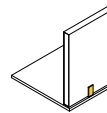

TOOL RAIL

Get the most out of your Basic table screen by adding one of our tool rails. With the tool rail you can attach holders, screens, shelves, and more to your table screen, enhancing the functionality and organisation of your workspace. Our tool rail comes in both integrated and outside mounted versions.

TOOL RAIL

BASIC ROUNDED &
SQUARE 30, 40 & 50

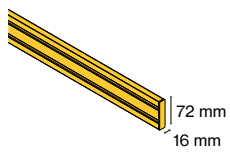

Outside mounted
art. no. 5400

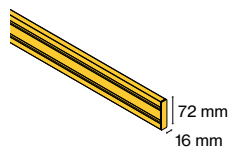
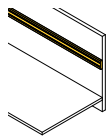

Integrated
art. no. 5500

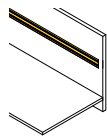

ACOUSTIC PROPERTIES

The ISO TEST 354 graphs showcases the impressive sound absorption of our Acoustic Table Screens, highlighting their ability to improve room acoustics across various frequencies for a quieter and more focused environment.

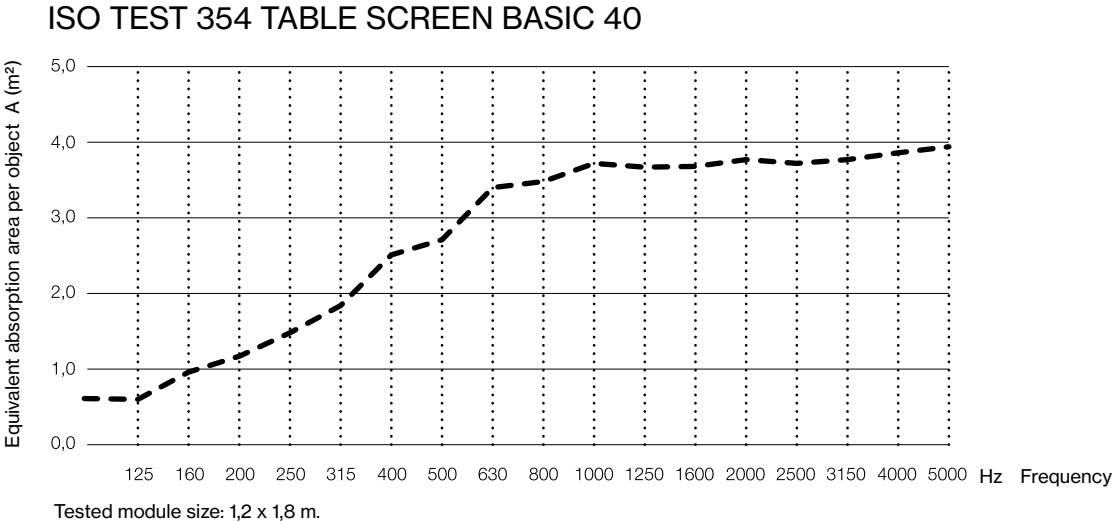
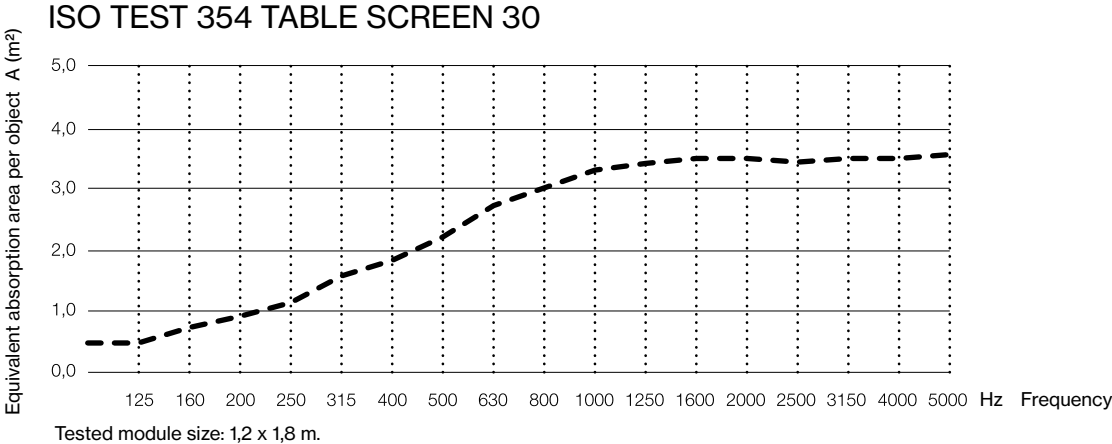

ACOUSTIC PROPERTIES

